

PLATFORM ACCESSORIES

Accessories

Code	Description
TB60	Low cart for a movable scale with 400x400 and 400x500 platforms. Height from ground to platform top: 250 mm
TB60EX	Low cart (atex Ex II 2GD IIB version) for a movable scale with 400x400 and 400x500 platforms. Height from ground to platform top: 250 mm
TB60I	Stainless steel low cart for 400x400 and 400x500 platforms. Height from ground to platform surface: 260 mm
TB60IEX	Stainless steel low cart (atex Ex II 2GD IIB version) for 400x400 and 400x500 platforms. Height from ground to platform surface: 260 mm
TB60B	Low cart for 500x 500 platforms. Height from ground to platform surface: 260 mm
TB60BEX	Low cart (atex Ex II 2GD IIB version) for 500x 500 platforms. Height from ground to platform surface: 260 mm
TB60BI	Stainless steel low cart for 500x 500 platforms. Height from ground to platform surface: 260 mm
TB60BIEX	Stainless steel low cart (atex Ex II 2GD IIB version) for 500x 500 platforms. Height from ground to platform surface: 260 mm
TB300	Low cart for a movable scale with 500x600 and 600x600 platforms. Height from ground to platform top: 270 mm
TB300EX	Low cart (atex Ex II 2GD IIB version) for a movable scale with 500x600 and 600x600 platforms. Height from ground to platform top: 270 mm
TB300I	Stainless steel low cart for 500x600 and 600x600 platforms. Height from ground to platform surface: 270 mm
TB300IEX	Stainless steel low cart (atex Ex II 2GD IIB version) for 500x600 and 600x600 platforms. Height from ground to platform surface: 270 mm
TA60	High cart for a movable scale with 400x400 and 400x500 platforms. Height from ground to platform top: 650 mm
TA60EX	High cart (atex Ex II 2GD IIB version) for a movable scale with 400x400 and 400x500 platforms. Height from ground to platform top: 650 mm
TA60I	Stainless steel high cart for 400x400 and 400x500 platforms. Height from ground to platform surface: 650 mm
TA60IEX	Stainless steel high cart (atex Ex II 2GD IIB version) for 400x400 and 400x500 platforms. Height from ground to platform surface: 650 mm
TA300	High cart for a movable scale for 500x600 and 600x600 platforms. Height from ground to platform top: 650 mm
TA300EX	High cart (atex Ex II 2GD IIB version) for a movable scale for 500x600 and 600x600 platforms. Height from ground to platform top: 650 mm
TA300I	Stainless steel high cart for 500x600 and 600x600 platforms. Height from ground to platform surface: 650 mm.
TA300IEX	STAINLESS STEEL high cart (atex Ex II 2GD IIB version) for 500x600 and 600x600 platforms. Height from ground to platform surface: 650 mm.
TPBEI	Stainless steel scale/labeller support plate for TA/TB carts
RF50X65	ROLLER UNIT with galvanised ø 32 idle rollers and 75 mm pitch, on a painted frame. Dimensions 500x650 mm.
RF50X65I	STAINLESS STEEL ROLLER UNIT with PVC ø 40 idle rollers and 75 mm pitch, on stainless steel frame. Dimensions 500x650 mm.

MODELLO TA

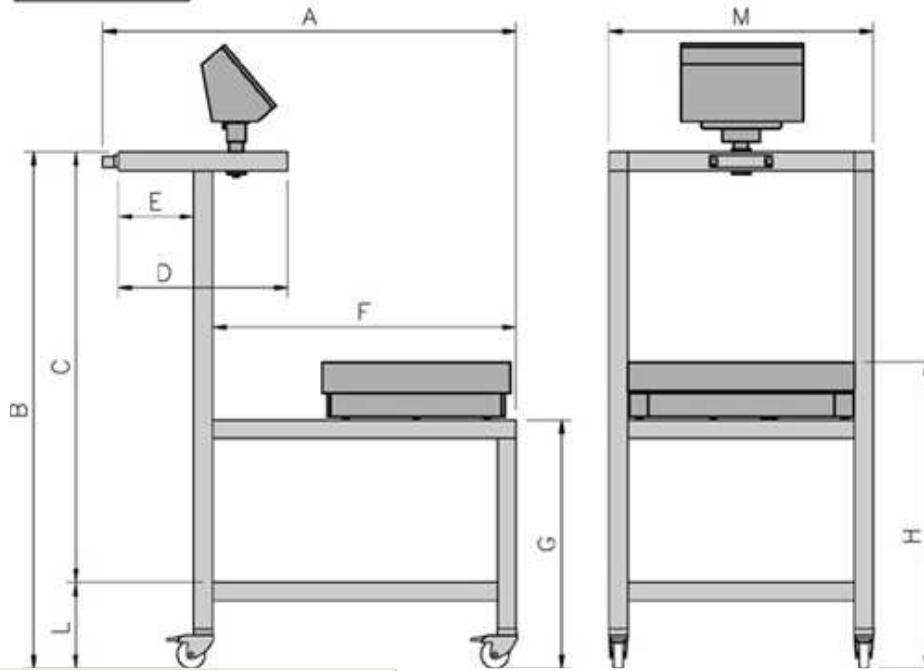

	A	B	C	D	E	F	G	H	L	M
TA60	880	1100	915	360	160	645	530	650	183	562
TA300	1030	1100	915	360	160	795	530	650	183	660

dimensions in mm

MODELLO TB

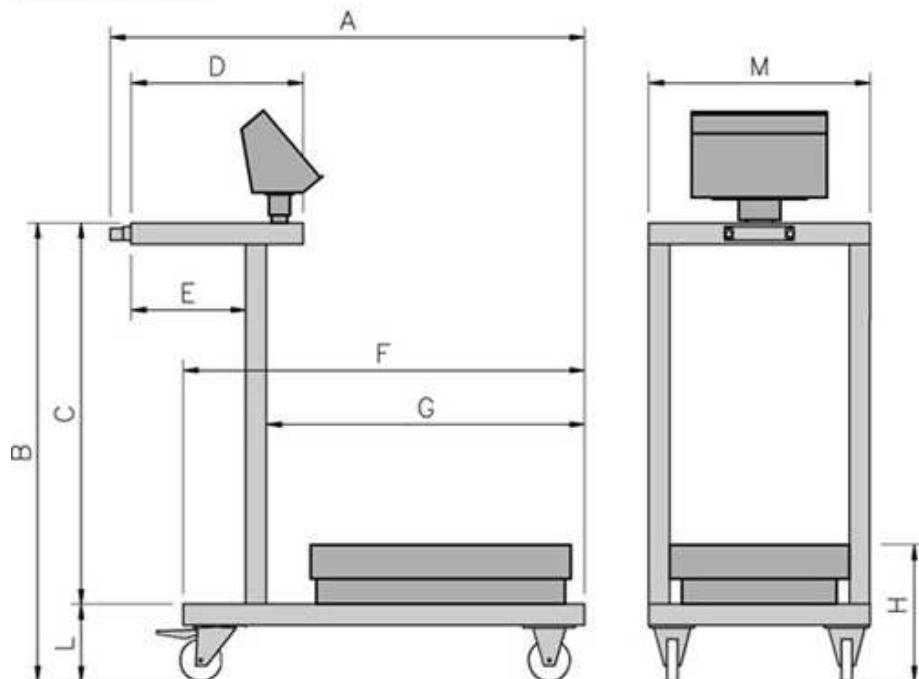

	A	B	C	D	E	F	G	H	L	M
TB60	910	880	730	330	220	770	610	270	150	425
TB60B	910	880	730	330	220	770	610	270	150	565
TB300	990	880	730	330	220	842	690	270	150	670

dimensions in mm