

MCW09 "PROFESSIONAL" STAINLESS STEEL CRANE SCALE SERIES



MCW09: IP67 stainless steel crane scales, with optional radio frequency module.

Stainless steel crane scales, with 40mm DOT LED large display, for maximum visibility from all angles and in any lighting condition, including direct sunlight. Sturdy and reliable, usable indoors as well as outdoors. Minimum reduction of the crane's lifting space. IP67 protection against dust and sprays. Fitted with test certificate obtained with sample weights, up to 15000 kg of capacity.

MAIN FEATURES

- **Extremely bright large red DOT LED 40mm display**, which guarantees a perfect visibility of the weight from any angle, also from a long distance.
Usable indoors as well as outdoors, great visibility also in full sunlight.
- **Adjustable brightness intensity.**
- **Sturdy STAINLESS steel structure**, with IP67 protection degree of the load cell and the electronics, against dust and sprays.
- **Fitted with approved galvanised shackles.**
- Extremely reduced distance between upper and lower shackles.
- Precision: +/- 0.03% on F.S.
- 5-key waterproof keypad: ZERO, AUTOMATIC TARE, MODE, PRINT, and ON/OFF.
- **Programmable digital filter**, for an excellent weight visualisation in any working condition.
- Programmable automatic switch-off function, either through keypad or remote control.
- **Fitted remote control**, configurable as just an automatic tare or as a 4-key remote keypad.
- Predisposed for an 868MHz **radio interface** or WiFi, for connection to PC or to a remote terminal and printer.
- Rechargeable battery, with an average life of about 30 hours.
- Predisposed for a second optional extractable battery for 24/7 continuous use.
- Fitted with 230Vac 50 Hz battery charger.
- Programmable digital calibration and Set-Up directly from the keypad or from PC through Dinitools.
- Operating temperature range: -10/+40 °C.

DIMENSIONS IN MM

Dimensions in mm.

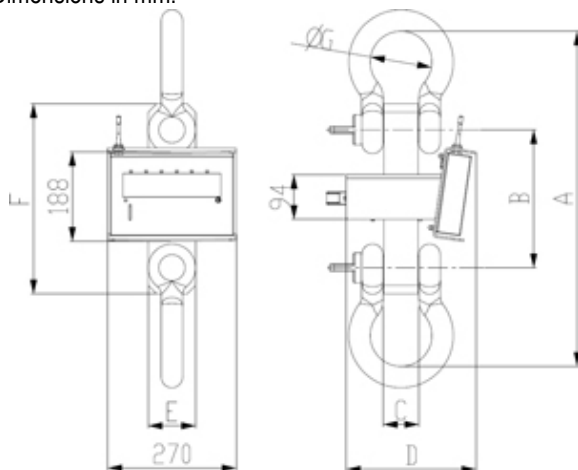

Code	A	B	C	D	E	F	G	Weight (kg) *
MCW09T12	451	186	52	272,5	100	270	83	30
MCW09T17	592	220	61	272,5	100	320	98	40
MCW09T25	640	290	75	272,5	100	400	130	56
MCW09T35	730	280	82	272,5	105	400	130	70
MCW09T55	1350	350	105	292,5	130	620	180	150

* including the packing and the shackles

SELECTABLE FUNCTIONS

- PEAK (maximum value read).
- HOLD (lock of the displayed weight).
- Weighing totalization.
- lb/kg conversion (see DFW weight indicators for more functions).
- +/- checkweighing.
- Percentage weighing.
- Counting.
- Peer-to-peer.
- High Resolution Weighing x 10.

**OPTIONS AVAILABLE UPON REQUEST ONLY
TOGETHER WITH THE ORDER**

- Radio frequency weight transmission to remote indicator, up to 70m indoors.
- 868Mhz radio interface.
- WI-FI interface.
- Remote weight indicator connected in radio frequency, (see DFW..., 3590..., TRS..., DGT60.. series' weight indicators) with the printer or other accessories.

Available versions

Code	Max Capacity kg	Standard Division kg	HR Division kg
MCW09T12	12000	5	2
MCW09T17	17000	10	5
MCW09T25	25000	10	5
MCW09T35	35000	20	10
MCW09T55	55000	20	10

Indicator connectable with MCW09 through optional radio transmission

Code	Description
DFWPM	Portable radio frequency weight repeater, for DFW indicators and MCW crane scales. Handy, compact, easy to use and consult.
DFWPMUSB	Portable radio frequency weight repeater, for DFW indicators and MCW crane scales. Handy, compact, easy to use and consult. Fitted with USB port for quick connection to PC.
DFW06XPCA	5 keys, LCD 25mm backlit display, built-in rechargeable battery, IP65 enclosure, 4-channel A/D converter, RS232 RJ plug, external 110-240 Vac adapter

Options only available at time of order

Code	Description
OBMMCI	Memory Data Printer option box in Stainless Steel with memory card for easy storage and transfer of the weighs to any Personal Computer (complete of memory card)
EHR	High resolution model for internal factory use
WIFIT	WI-FI interface for wireless connection (through access point) to the company computer system.
RFITR	Integrated radio interface for crane scale/pallet truck scale , complete of RS232 port. Max. functioning distance in appropriate conditions: 70m indoors, 150m outdoors. Up to 50 configurable channels (must be combined with another radio modem)
OBRF	External radio interface, fitted in ABS case with IP65 protection and a 3-metre cable, for weight indicator/repeater . Max. functioning distance in adequate conditions: 70m indoors, 150m outdoors. Up to 50 configurable channels (OBRF must be combined with another radio modem).
OBRFUSB	868MHz radio frequency module for PC with USB input, selfpowered, connectable to USB ports. Fitted with USB connection cable. Max. functioning distance in appropriate conditions: 70m indoor, 150m outdoor. 50 available channels, easily programmable from the PC.
OBRF232	868 MHz radio frequency module for PC with RS232 9-pole input, connectable to RS232 ports. Fitted with connection/power supply cable. Max. functioning distance in appropriate conditions: 70m indoors, 150m outdoors. 50 available channels, easily programmable from PC.
DFCLK	Real Time Clock (Time/date)
ALMEM	Alibi memory (fiscal memory) with time/date; max. 120.000 weighs
MCWKBK	Backup battery kit for MCWK, including the spare battery pack and battery charger, for continuous use of the crane scale.

Accessories

Code	Description
GG15	Swivelling bottom hook with safety lock 15 t
GG22	Swivelling bottom hook with safety lock 22 t
GG30	Swivelling bottom hook with safety lock 30 t
CA15	Connection ring 15 t
CA30	Connection ring 30 t
CA40	Connection ring 40 t