

## MCWATEX2GD SUSPENDED CRANE SCALES



Industrial crane scales for use in areas classified as hazardous (Zone 1 and 21, 2 and 22) in accordance with Ex II 2GD IIC T4 T197°C X protection.

LITTLE SPACE IS TAKEN UP allowing the best use of the lifting devices. Predisposed for an upper connection ring and lower hook. Fitted with test certificate obtained with sample weights, up to 15000 kg of capacity.

### MAIN FEATURES

- Indicator with 17-key numeric-functional waterproof keyboard.
- LCD display with 6 25-mm high contrast digits and icons for showing the active functions.
- Precision: +/- 0.03% F.S.
- Built extremely sturdy in oven-fire painted sheet steel.
- Digital set-up and calibration programmable directly from keyboard using a sample weight.
- Operating temperature: -10 /+40 °C.
- Adjustable digital filter, anti vibration and oscillation.
- Programmable auto power saving function.
- Hermetically sealed rechargeable battery, with 160-hour operating time; rechargeable in safe area.
- Equipped with 230Vac 50 Hz battery charger to be used in safe area.

### KEYBOARD FUNCTIONS

- Zeroing.
- Automatic Tare.
- Presetable Tare.
- Tare database (up to 10).
- ID1 and ID2 10-digit Codes.
- Selectable function command.
- On/off switching.

### SELECTABLE FUNCTIONS

- Simple display and/or with sensitivity HR x 10.
- Net/Gross.
- lb/kg conversion.
- Weighs accumulation (with up to 10 storage values).
- Formula weighing.
- Counting with function of entering the known A.P.W.
- Hold.

MCWATEX with optional ring and swivelling hook

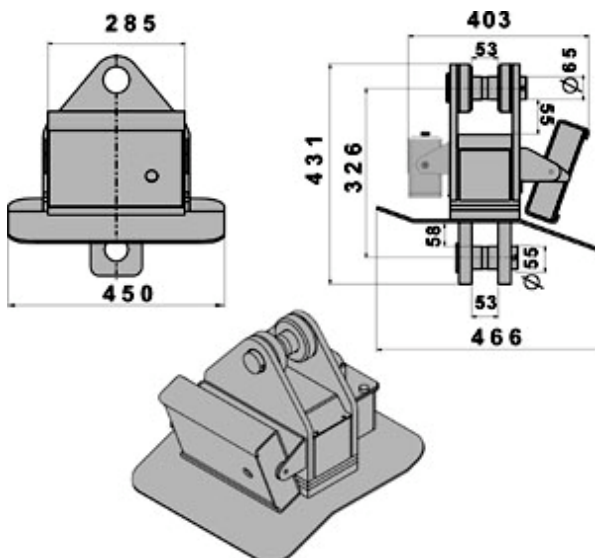

MCWATEX - dimensions in mm

### Available versions

Code	Max Capacity kg	Division kg	HR Division kg	CE-M Division kg
MCWATEX152GD	15000	5	2	
MCWATEX252GD	25000	10	5	
MCWATEX352GD	35000	20	10	
MCWATEX152GDM <b>M</b>	15000			5

**Options only available at time of order**

Code	Description
DFWBP76ATEX	Rechargeable ATEX battery from 9,6 Vdc and 7600 mAh for weight indicator, pallet truck scale, or crane scale. NOTE: Recharge of the battery pack allowed only in a safe area. In the applications with the weight indicator mounted on a column or cart, the installation requires the STFA bracket.

**Accessories**

Code	Description
GG15	Swivelling bottom hook with safety lock 15 t
GG22	Swivelling bottom hook with safety lock 22 t
GG30	Swivelling bottom hook with safety lock 30 t
CA15	Connection ring 15 t
CA30	Connection ring 30 t
CA40	Connection ring 40 t

**MEASUREMENTS OF HOOKS AND RINGS IN MM**

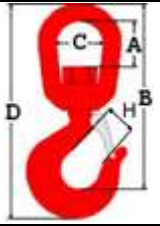
	Code	A	B	C	D	H
	GG15	95	354	96	455	63
	GG22	121	432	120	565	80
	GG30	133	568	139	667	88
	CA15	174	110	200		
	CA30	270	180	340		