

**MCW "PROFESSIONAL" SERIES SUSPENDED CRANE SCALES**



Stainless steel crane scales, reliable and easy to use, suitable for indoor and outdoor use (IP67 dust and rain resistant). For capacities up to 6000 kg, the models are available both for internal factory use as well as CE-M APPROVED.

Fitted with test certificate obtained with sample weights.

**MAIN FEATURES**

- Large backlit 25mm LCD display easily visible in all lighting conditions and also with low temperatures.
- Fitted with approved upper galvanized shackle and approved bottom swivelling hook (for the capacities from 150 to 6500 kg).
- Precision: +/- 0.03% F.S.
- Waterproof keyboard with 5 keys: ZERO, AUTOMATIC TARE, MODE, PRINT, and ON/OFF.
- **Function mode configurable as PEAK (maximum value read), HOLD (blocking the weight viewed), Weighs accumulation, lb/kg conversion (for other available functions see DFW indicator).**
- IP67 STAINLESS STEEL case (dust and rain).
- Fitted with remote control for up to a 8 m distance. The remote control may be configured by the customer as automatic tare only, or as a remote keypad with 4 keys.
- Rechargeable hermetically sealed battery with a 40-hour operating time.
- Digital set-up and calibration programmable directly from keyboard using a sample weight.
- Operating temperature: -10 /+40 °C.
- Programmable digital filter and auto switch-off.
- Equipped with 230Vac 50 Hz battery charger.

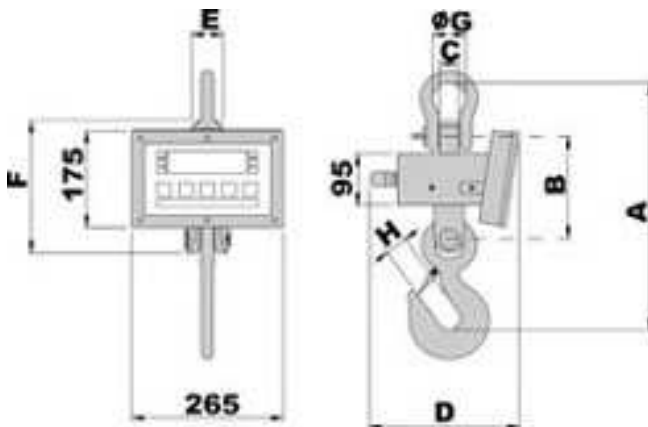

MCW dimensions (capacities 150 - 6500 kg)

**WEIGHTS AND MEASUREMENTS**

Code	A	B	C	D	E	F	G	H	Weight in kg (including packing)
MCW150	321	160	24	260	45	200	43	30	10
MCW300	321	160	24	260	45	200	43	30	10
MCW600	321	160	24	260	45	200	43	30	10
MCW1500	390	160	34	260	45	200	58	38	16
MCW3000	450	187	34	260	55	240	58	38	16
MCWT6	450	187	34	260	55	240	58	45	16

N.B.: the approved models have the same dimensions as those for internal use

**OPTIONS ONLY AVAILABLE AT TIME OF ORDER**

- RF weight transmission to remote indicator up to over 70m indoors
- WI-FI interface
- Attached thermal printer option box
- Remote weight indicator (see DFW..., 3590..., TRS..., DGT60.. Series' indicators) with printer connected through radio frequency

**Available versions**

Code	Max Capacity kg	Standard Division kg	HR Division kg	CE-M Division kg
MCW150	150	0,05	0,02	
MCW300	300	0,1	0,05	
MCW600	600	0,2	0,1	
MCW1500	1500	0,5	0,2	
MCW3000	3000	1	0,5	
MCWT6	6500	2	1	

MCW150M <b>M</b>	150	0,05
MCW300M <b>M</b>	300	0,1
MCW600M <b>M</b>	600	0,2
MCW1500M <b>M</b>	1500	0,5
MCW3000M <b>M</b>	3000	1
MCWT6M <b>M</b>	6000	2

#### Indicator connectable with MCW through optional radio transmission

Code	Description
DFWPM	Portable radio frequency weight repeater, for DFW indicators and MCW crane scales. Handy, compact, easy to use and consult.
DFWPMUSB	Portable radio frequency weight repeater, for DFW indicators and MCW crane scales. Handy, compact, easy to use and consult. Fitted with USB port for quick connection to PC.
DFW06XPCA	5 keys, LCD 25mm backlit display, built-in rechargeable battery, IP65 enclosure, 4-channel A/D converter, RS232 RJ plug, external 110-240 Vac adapter

#### Options only available at time of order

Code	Description
OBTPRI	<b>Attached</b> thermal printer STAINLESS STEEL option box with >50mm/sec speed, 203 dpi resolution, 24/40 columns, 58 mm paper width; 50 mm Roll diameter
OBMCCI	Memory Data Printer option box in <b>Stainless Steel</b> with memory card for easy storage and transfer of the weighs to any Personal Computer (complete of memory card)
EHR	High resolution model for internal factory use
WIFIT	WI-FI interface for wireless connection (through access point) to the company computer system.
RFITR	<b>Integrated</b> radio interface for <b>crane scale/pallet truck scale</b> , complete of RS232 port. Max. functioning distance in appropriate conditions: 70m indoors, 150m outdoors. Up to 50 configurable channels (must be combined with another radio modem)
OBRF	External radio interface, fitted in ABS case with IP65 protection and a 3-metre cable, for <b>weight indicator/repeater</b> . Max. functioning distance in adequate conditions: 70m indoors, 150m outdoors. Up to 50 configurable channels (OBRF must be combined with another radio modem).
OBRFUSB868MHz	radio frequency module for PC with USB input, selfpowered, connectable to USB ports. Fitted with USB connection cable. Max. functioning distance in appropriate conditions: 70m indoor, 150m outdoor. 50 available channels, easily programmable from the PC.
OBRF232	868 MHz radio frequency module for PC with RS232 9-pole input, connectable to RS232 ports. Fitted with connection/power supply cable. Max. functioning distance in appropriate conditions: 70m indoors, 150m outdoors. 50 available channels, easily programmable from PC.
DFCLK	Real Time Clock (Time/date)
ALMEM	Alibi memory (fiscal memory) with time/date; max. 120.000 weighs
MCWLB	Version with 40mm red led digits (10/15 hour battery operating time)
MCWBK	Backup battery kit for MCW inclusive of spare battery pack and battery charger

#### Accessories

Code	Description
CA2	Connection ring 2.5 t
CA4	Connection ring 4 t
CA8	Connection ring 8 t

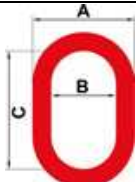
MEASUREMENTS OF HOOKS AND RINGS IN MM				
	Code	A	B	C
	CA2	86	60	110
	CA4	111	75	135
	CA8	152	100	180