

MCWX2GD SUSPENDED CRANE SCALES

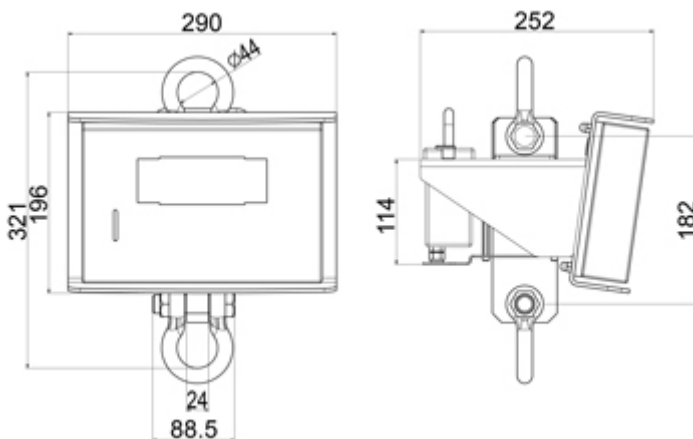

MCWX2GD



MCWX2GD - dimensions in mm.

Industrial crane scales for use in areas classified as hazardous (Zone 1 and 21, 2 and 22) in accordance with Ex II 2GD IIC T4 T197°C X protection.

Structure completely in stainless steel, with IP68 protection degree. LITTLE SPACE IS TAKEN UP allowing the best use of the lifting devices. Predisposed for an upper connection ring and lower hook.

MAIN FEATURES

- Indicator with 17-key numeric-functional waterproof keyboard.
- LCD display with 6 25-mm high contrast digits and icons for showing the active functions.
- Precision: +/- 0.03% F.S.
- Built extremely sturdy in IP68 stainless steel.
- Fitted with upper and lower shackle.
- Digital set-up and calibration programmable directly from keyboard using a sample weight.
- Operating temperature: -10 /+40 °C.
- Adjustable digital filter, anti vibration and oscillation.
- Programmable auto switch-off power for energy saving.
- Hermetically sealed extractable rechargeable battery, with 160-hour operating time; rechargeable in safe area.
- Equipped with 230Vac 50 Hz battery charger to be used in safe area.

KEYBOARD FUNCTIONS

- Zeroing.
- Automatic Tare.
- Presetable Tare.
- Tare database (up to 10).
- ID1 and ID2 10-digit Codes.
- Selectable function command.
- On/off switching.





SELECTABLE FUNCTIONS

- Simple display and/or with sensitivity HR x 10.
- Net/Gross.
- lb/kg conversion.
- Weighs accumulation (with up to 10 storage values).
- Formula weighing.
- Counting with function of entering the known A.P.W.
- Hold.

OPTIONS AND ACCESSORIES

- Additional rechargeable battery pack, for use the crane scale 24/7.
- Swivelling bottom hook.
- Connection ring.

Available versions

| Code | Max Capacity [kg] | Division [kg] | HR Division [kg] | CE-M Division [kg] |
|---|-------------------|---------------|------------------|--------------------|
| MCWX2GD600 | 600 | 0,2 | 0,1 | |
| MCWX2GD1T5 | 1500 | 0,5 | 0,2 | |
| MCWX2GD3T | 3000 | 1 | 0,5 | |
| MCWX2GD6T | 6000 | 2 | 1 | |
| MCWX2GD600M  | 600 | | | 0,2 |
| MCWX2GD1T5M  | 1500 | | | 0,5 |
| MCWX2GD3TM  | 3000 | | | 1 |
| MCWX2GD6TM  | 6000 | | | 2 |

Options only available at time of order

| Code | Description |
|-------------|---|
| DFWBP76ATEX | Rechargeable ATEX battery from 9,6 Vdc and 7600 mAh for weight indicator, pallet truck scale, or crane scale. NOTE: Recharge of the battery pack allowed only in a safe area. In the applications with the weight indicator mounted on a column or cart, the installation requires the STFA bracket. |

Accessories

| Code | Description |
|------|---|
| GG15 | Swivelling bottom hook with safety lock 15 t. |
| GG22 | Swivelling bottom hook with safety lock 22 t. |
| GG30 | Swivelling bottom hook with safety lock 30 t. |
| CA2 | Connection ring 2,5 t. |
| CA4 | Connection ring 4 t. |
| CA8 | Connection ring 8 t. |
| CA15 | Connection ring 15 t. |
| CA30 | Connection ring 30 t. |

MEASUREMENTS OF HOOKS AND RINGS IN MM

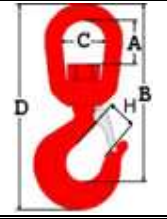
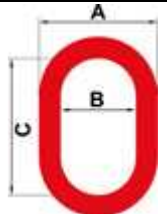
| | Codice | A | B | C | D | H |
|---|--------|-----|-----|-----|-----|----|
|  | GG15 | 95 | 354 | 96 | 455 | 63 |
| | GG22 | 121 | 432 | 120 | 565 | 80 |
| | GG30 | 133 | 568 | 139 | 667 | 88 |
|  | CA2 | 86 | 60 | 110 | | |
| | CA4 | 111 | 75 | 135 | | |
| | CA8 | 152 | 100 | 180 | | |
| | CA15 | 174 | 110 | 200 | | |
| | CA30 | 270 | 180 | 340 | | |