

TW SERIES OVERHEAD MONORAIL WEIGHING SCALES

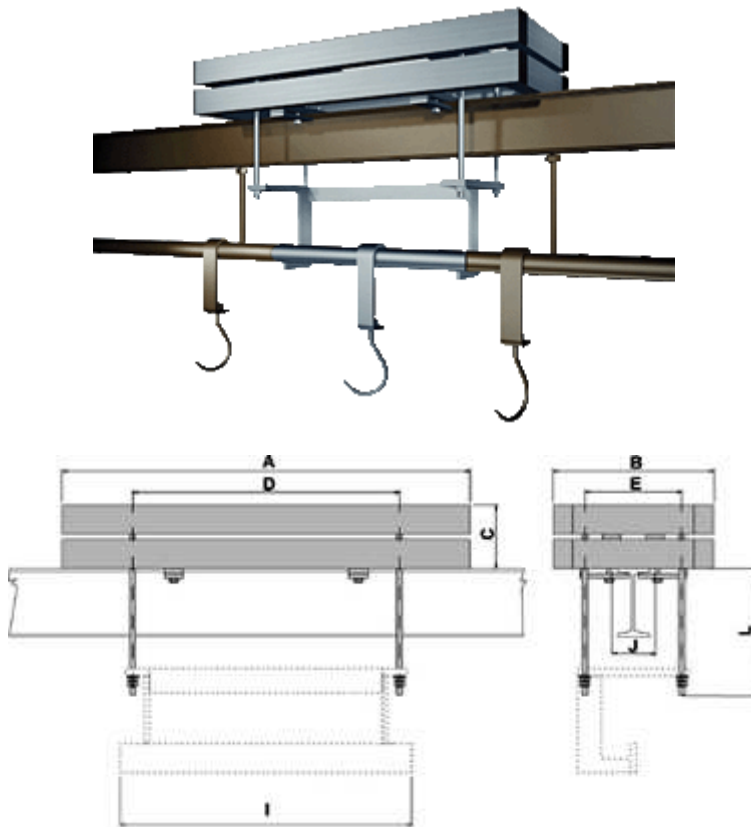

	A	B	C	D	E	I	J	L
TW	840	330	135	550	200	600	90	195
TWS	420	285	140	300	210	300	90	195

dimensions in mm

Low profile weighing modules for overhead monorails, easily adaptable with any type of monorail track systems, even already existing ones. Standard version is with approved load cell.

MAIN FEATURES





- Functions with 1 aluminium approved cell with protection according to IP66 standards (TWS model) or with 3 STAINLESS STEEL approved cells with IP68 protection (TW model) and according to OIMLR60 standards.
- Steel tubular structure fitted with fastening accessories that are electrolytically galvanised or in stainless steel.
- Up to 15 Vdc power supply.
- Hermetic junction box with screened 10m long 6-pin cable with connectors for connection to the weight indicator.
- The STAINLESS STEEL model has structure and fastening accessories in AISI304.

N.B.: The track section, on which the scale is installed, must be supplied by the customer, after the essential preliminary technical checks have been made. (see below).

OPTIONS ONLY AVAILABLE AT TIME OF ORDER

- Possible adaptations with customer's monorail system which will be quantified upon survey.
- Connection to the indicator and calibration with CE-M 3000e single range or 3000e+3000e dual range approval (with indicators of our production).
- Models with special sizes and capacities (ask for estimate).

Available versions

Code	Max. Track Length of l mm	Max Capacity kg	CE-M Division g (*)	CE-M2 Division g (*)
TWS15	300	150	50	20-50
TWS30	300	300	100	50-100
TW30	600	300	100	
TW60	600	600	200	100-200
TWSI15 	300	150	50	20-50
TWSI30 	300	300	100	50-100
TWI30 	600	300	100	
TWI60 	600	600	200	100-200

(*) These divisions are obtainable only with the relative options

Options only available at time of order

Code	Description
ECEM1B	CE-M 3000e initial stamping for class III or IIII scales with capacity from 31 to 1500 kg
ECEM2B	CE-M 2x3000e initial stamping for class III or IIII scales with capacity from 31 to 1500 kg

PRELIMINARY TECHNICAL CHECKS

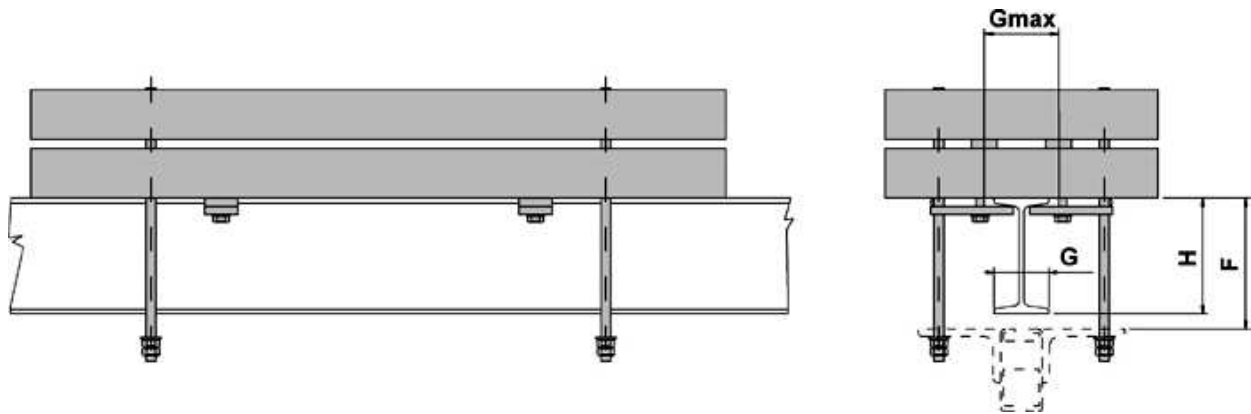

Data to communicate for adapting the track

1) Distance from the overhead weigh resting surface and the upper part of the track section: F= mm _____

2) Dimensions of beam:
G= mm _____ H= mm _____ type (if commercial): _____

3) Track section:
Send a drawing with the dimensions of the track section
